

# 3 PANEL STACKER DOOR

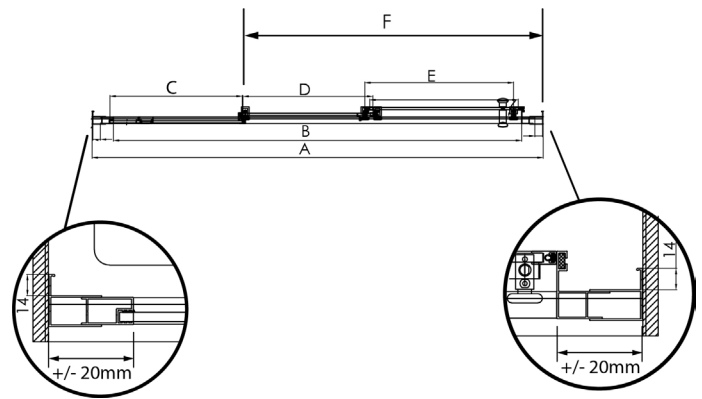

Pictured above - Stellar 3 Panel Stacker Door Silva



## DESCRIPTION

The Stellar 3 Panel Stacker Door can be purchased on its own and is a perfect door replacement when renovating an existing Alcove Shower.

A Return Panel can also be added to create a custom size 2 Sided Shower.

## FEATURES

- Internal slider
- Door is reversible and can open left to right or right to left
- Standard heights 1950mm/1830mm
- No door swing out into the bathroom dripping water onto the floor
- Water drains back into the shower
- Door panels go behind the bottom extrusion to eliminate splash-back out the bottom of the shower door
- Approx 15mm adjustment allowing for out of plumb walls
- Stylish chrome handle
- New roller assembly ensures greater reliability and smooth functionality
- 6mm Safety Glass compliant to AS/NZS2208
- Silva finish only

## LEGEND

Dimension	Description	Door Size		
		900mm	1000mm	1200mm
A	Maximum Outside Frame Width	880mm	980mm	1180mm
B	Internal Frame Width	768mm	868mm	1068mm
C	Fixed Panel Width	246mm	280mm	346mm
D	Centre Sliding Panel Width	240mm	273mm	340mm
E	Outer (handle) Panel Width	289mm	322mm	288mm
F	Door Opening Dimension	417mm	484mm	617mm

## ORDERING CODES

Product Description	SKU		
	900mm	1000mm	1200mm
Door Only Silva (LH/RH Reversible) 1830mm High	119545	119546	173233
Door Only Silva (LH/RH Reversible) 1900mm High	288738	288739	288740

## WARRANTY INFORMATION

All bathroomware products supplied by Fibre Systems carry our Quality Assurance and Product Warranty. We use the highest quality materials available and manufacture these in accordance with New Zealand specifications and requirements to ensure that all products are fit for the intended purpose for which they are designed. Our customer's peace of mind is of paramount importance to us.

### Warranty Periods

Baths	10 years
Showers	10 years
Shower Screens and Doors	10 years
Silva and White Coatings	10 years
E-Line + Squareline + Dezine Showers	5 years
Black Coatings	5 years
Aquaknight Easy Clean Wastes	7 years
Accessories	2 years



### Warranty Exclusions

The product must be installed according to the instructions supplied.

The water supply temperature applied to the product must not exceed 55 degrees Celsius.

All cleaning and cleaning products must be in accordance with our cleaning instructions and guidance.

Commercial Applications (where products are installed in a building where occupancy is via a commercial arrangement i.e. a rental property, hotel, hostel etc) are restricted to a 2 year warranty on all products.

## CLEANING AND MAINTENANCE

Please refer to our cleaning instructions document for guidance, available on our website

In accordance with our continuous product development programs, Fibre Systems sizes and specifications outlined in these specifications are subject to change without notice.

Information detailed in this technical sheet represents the actual product available at the time of printing this sheet. For the latest version of this technical sheet please visit [www.stellarshowers.co.nz](http://www.stellarshowers.co.nz) or contact your nearest Mitre 10 store to confirm any questions prior to purchase.